

**REGION OF QUEENS MUNICIPALITY
REGULAR COUNCIL
TUESDAY, AUGUST 11, 2015
9:00 A.M.**

PRESENT: Mayor Christopher Clarke, Chair
Councillor Darlene Norman
Councillor Brian Fralic
Councillor Jack Fancy
Councillor Peter Waterman
Councillor Susan MacLeod
Councillor Raymond Fiske
Richard MacLellan, Chief Administrative Officer
April Whynot-Lohnes, Municipal Clerk
Christine Watson, Recording / Management Secretary

REGRETS: Councillor Bruce Inglis

1.0 CALL TO ORDER:

Mayor Clarke called the meeting to order at 9:00 a.m.

2.0 CHANGES / APPROVAL OF AGENDA:

It was moved by Councillor Waterman and seconded by Councillor Fralic that the Agenda be approved as presented:

MOTION CARRIED unanimously.

3.0 PRESENTATION(S):

3.1 Unify Energy Inc. – Liverpool Wind Energy Storage Project – Stan Mason

Stan Mason, President and Director of Unify Energy Inc. was welcomed to Council by Mayor Clarke and presented an update on the Liverpool Wind Energy Storage Project (copy of presentation is attached to original set of Minutes).

Unify partnered with LightSail Energy, developer of Regenerative Air Energy Storage (RAES) in 2014. They have a 20 year contract with Nova Scotia Power under the COMFIT (Community Feed-in Tariff) program.

They have set up their site in the old mixing room in the former Bowater Mersey site which will consist of containers to capture heat, water storage and air storage. They will be capturing and storing the excess steam from Brooklyn Energy Corp, and are anticipating that they will be in full operation by 2017. They do not anticipate any issues on the financing for the \$14 Million project.

Deputy Mayor Norman asked that since the government is closing the books on future COMFIT programs, if this would have any effect on their project. Mr. Mason indicated that they have secured a fixed contract with Nova Scotia Power for 20 years and they would not be affected.

Councillor MacLeod questioned whether there are any considerations for manufacturing the storage units in Queens County. Mr. Mason indicated that they hope to expand the operations and there may be opportunities for manufacturing in Queens.

Mayor Clarke questioned if there had been any concerns during the Environmental assessments. Mr. Mason indicated they had discovered bats, and that due to the decline in the bat population, they have installed special bat monitors on the tower to monitor for movement, and that they may have to curtail the turbine at times because of this.

Mayor Clarke thanked Mr. Mason for attending and updating Council.

4.0 TABLING OF PETITIONS:

There were no petitions to come before this meeting.

5.0 PUBLIC QUESTION / COMMENT SESSION:

David Dagley, 9 Meadow Pond Lane, Liverpool

Mr. Dagley asked if there is any policy that may restrict the Region of Queens from investing tax payers money in infrastructure outside of Queens.

The Mayor indicated that to his knowledge there was not.

Bill Cox, 121 Bog Road, White Point

Mr. Cox asked if under Item 15.1, would background and purpose be provided, and the energy projects be explained.

Leon Robertson, 45 College Street, Liverpool

Mr. Robertson asked if the ending of the COMFIT program would affect Chester's project.

Mayor Clarke indicated that the CAO had indicated presently no.

6.0 APPROVAL OF MINUTES:

6.1 Council Minutes – July 28, 2015

It was moved by Councillor Waterman and seconded by Councillor Fancy:

THAT the minutes of the Regular Council meeting held on July 28, 2015 be approved as circulated.

MOTION CARRIED unanimously.

7.0 DANGEROUS OR UNSIGHTLY PREMISES:

There were no Dangerous or Unsightly Premises matters to be discussed at this meeting.

8.0 ECONOMIC DEVELOPMENT:

8.1 UNSM Resolution on Rural Internet

It was moved by Councillor Norman and seconded by Councillor Fralic:

THAT Council approves the Resolution respecting the Provision of Internet to Rural Areas of Nova Scotia; and that we forward same to the Union of Nova Scotia Municipalities (UNSM) for consideration by the membership at the 2015 Fall Conference of UNSM.

Councillor Norman stated staff have prepared a background paper to be submitted with the resolution to UNSM for the fall conference.

Ms. Cruikshank, Director of Economic Development, provided a brief review of the resolution and the process for submitting to UNSM.

It was noted that Chester Municipality is also submitting a resolution and they are looking at the same issues.

MOTION CARRIED unanimously.

9.0 CORPORATE SERVICES:

There were no items discussed at this meeting.

10.0 ENGINEERING AND WORKS:

There were no items discussed at this meeting.

11.0 FINANCE

There were no items discussed at this meeting.

12.0 RECREATION AND COMMUNITY FACILITIES:

Councillor Fralic announced that the annual concert series at the Astor will start this week and will go into the fall.

Councillor Fancy commented that Sarah Mitton placed 4th in the Junior Pan Am games and asked if it would be appropriate to send a letter of congratulations. Mayor Clarke indicated that if Council gave that direction, he would send a letter.

13.0 PLANNING:

13.1 Amend Land Use Bylaw – Dog Grooming/Training in Light Industrial (M1) Zone

It was moved by Councillor MacLeod and seconded by Councillor Fralic:

THAT the Council of the Region of Queens Municipality adopt a bylaw respecting amendments to the Region of Queens Municipality Land Use Bylaw, which would see:

- 1. Inserting a definition for pet care services; and**
- 2. Including pet care services in the list of permitted uses in the Light Industrial (M1) Zone.**

MOTION CARRIED unanimously.

14.0 QUEENS PLACE EMERA CENTRE:

There were no items discussed at this meeting.

15.0 REPORTS:

15.1 Renewable to Retail Project Development with District of Chester

Richard MacLellan, CAO, indicated that the report is an update on renewable to retail regulations and possible project development that the District of Chester has approached the Region of Queens Municipality on.

The 2013 Electricity Reform Act opened up opportunities for independent power producers to sell electricity to customers using the Nova Scotia Power electrical grid. The regulations and the tariff associated to the opportunity are under development, with consultations being led by Nova Scotia Power. It is expected that the tariff and regulations will be finalized in the fall of 2015. District of Chester has been given direction to develop a potential project and seek partners. In June 2015, the proposed concept was presented to a number of South Shore municipalities for consideration. The request from District of Chester is for municipalities to confirm interest in participating in project development.

Jennifer Keating-Hubley, Director of Finance, clarified that the District of Chester had approached the Region, as well as a number of other municipalities, to see if there was an opportunity for partnership on wind turbine installations. Region of Queens Municipality remains in discussions with them, looking at the various financial models that are being presented by an independent consultant, and will not enter into a retail or commercial type agreement until there is a confidence on its financial viability.

16.0 OTHER:

16.1 Canada 150 Funds

Information on celebrating Canada's 150 was circulated to Council members for review.

Richard MacLellan, CAO, said that a report is being prepared by staff and will be presented at the second Council meeting in September.

17.0 IN-CAMERA ITEMS

There were no items discussed at this meeting.

18.0 ADJOURNMENT

There being no further business, the meeting adjourned at 10:29 a.m.

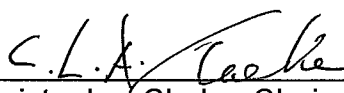

Mayor Christopher Clarke, Chair



April Whynot-Lohmes, Municipal Clerk

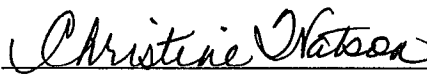

Christine Watson, Recording / Management Secretary

Date Approved: 

Liverpool Wind Energy Storage Project



Project Update For:
The Council of the Region of Queens
Liverpool, Nova Scotia
August 11, 2015

Liverpool Wind Energy Storage Project



- Unify Energy is a turnkey energy storage developer.
- Partnered with LightSail Energy, VC backed technology developer of Regenerative Air Energy Storage (RAES)
- Established partnership with Unify in 2014

UNIFY ENERGY INC.

www.unifyenergy.ca

Liverpool Wind Energy Storage Project

Regenerative Air Energy Storage

- 80% efficiency
- Low capital cost
- Robust service and cycle life
- Modular power and energy systems
- Flexible and agile operating parameters
- Chemically inert materials

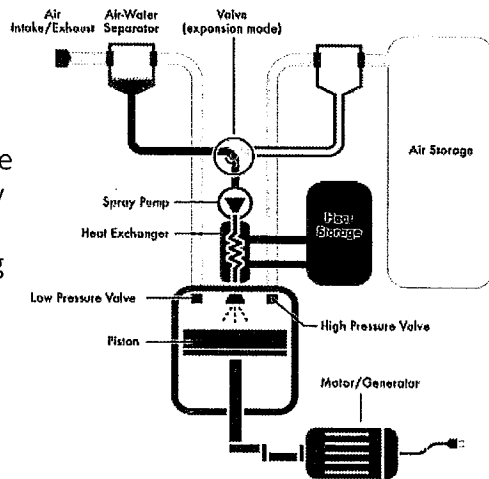

UNIFY ENERGY INC.

www.unifyenergy.ca

Liverpool Wind Energy Storage Project

Why Storage?

Wind energy penetration rates are rising
 → Existing electrical infrastructure under stress
 → Value of wind energy decreases

Use storage to extend installable WEC capacity on distribution grid in NS.

UNIFY ENERGY INC.

www.unifyenergy.ca

Liverpool Wind Energy Storage Project
Wind + RAES Demonstration Project

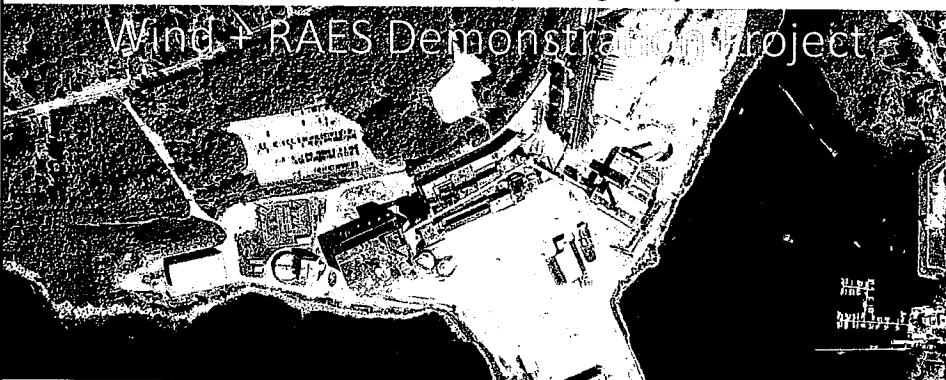

- Demonstration Project
- R&D Platform
- Commercial Energy Storage Facility
- COMFIT Project

UNIFY ENERGY INC. www.unifyenergy.ca

Liverpool Wind Energy Storage Project
Wind + RAES Demonstration Project

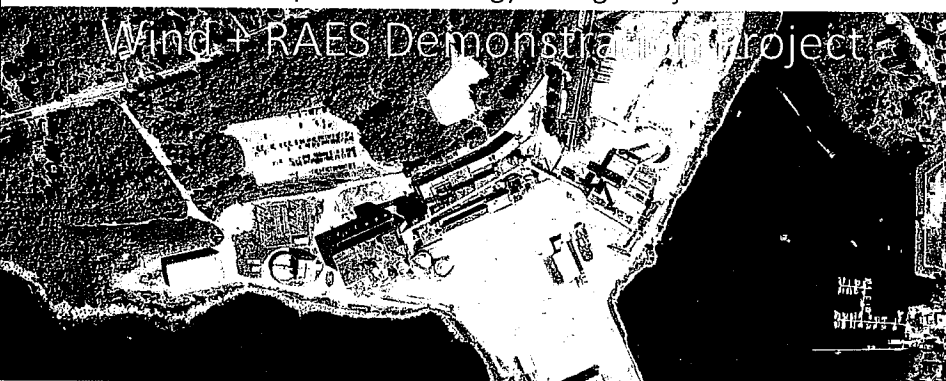

- 4.7 MW Wind Farm
- 0.5 MW Power / 4 MWh Energy
- 3.6 MW Capacity Limit

UNIFY ENERGY INC. www.unifyenergy.ca

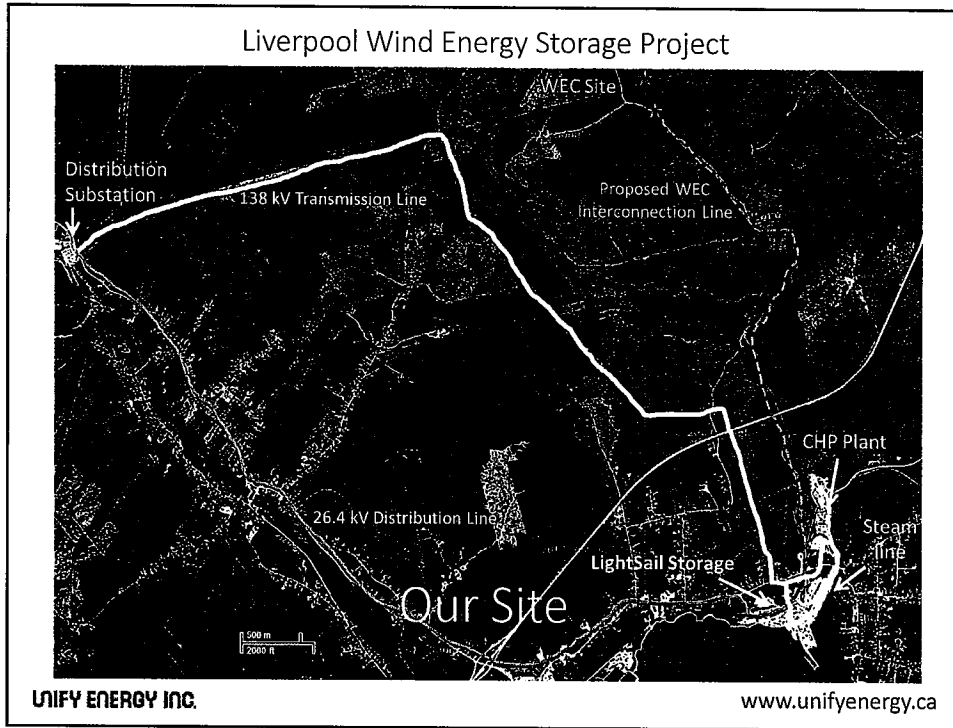

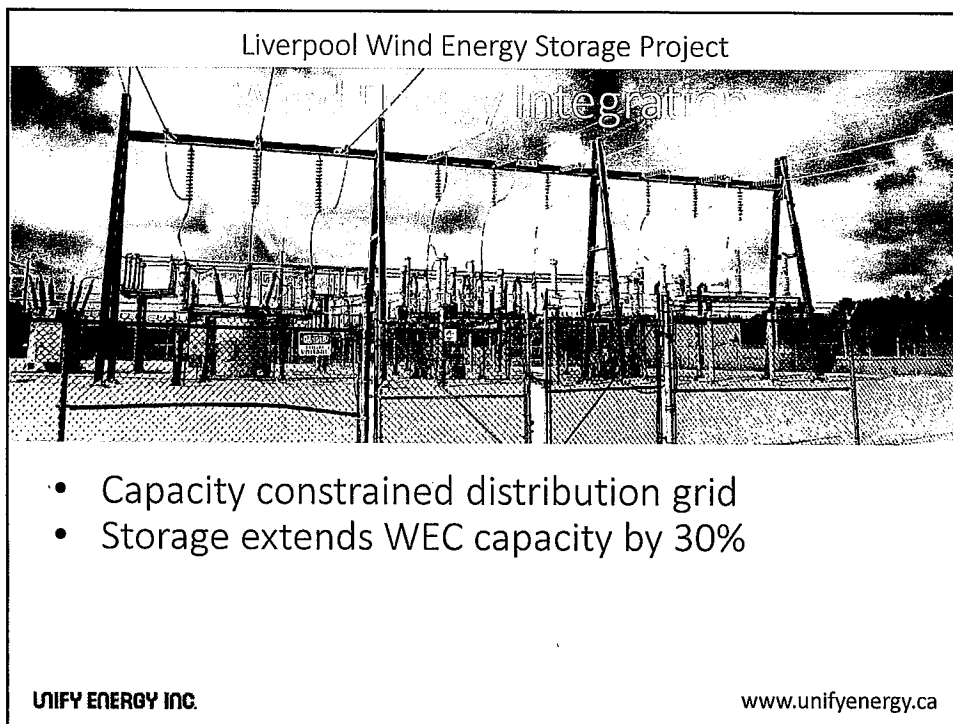
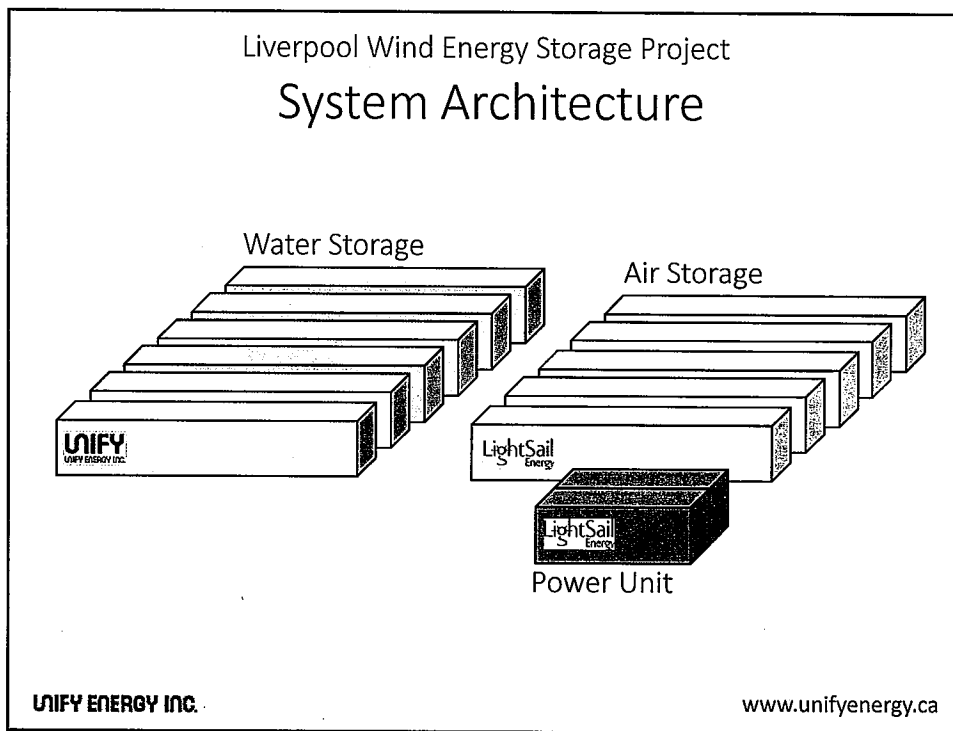

Liverpool Wind Energy Storage Project

Waste Heat Recovery

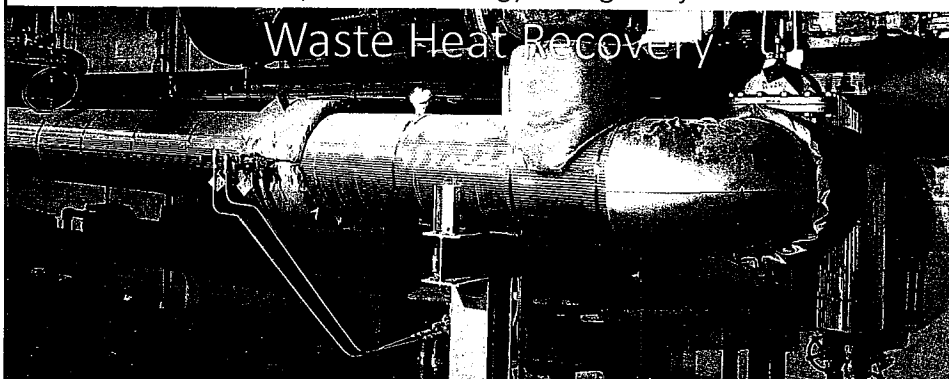

- Excess steam from Brooklyn CHP
- Increases efficiency from 60% to 80%
- Only used during expansion

UNIFY ENERGY INC.

www.unifyenergy.ca

Liverpool Wind Energy Storage Project

Cold Climate Operation



- First deployment RAES in a cold climate

UNIFY ENERGY INC.

www.unifyenergy.ca

Liverpool Wind Energy Storage Project

Advanced Control Strategy Development

- Control strategy to avoid WEC curtailment
- Wind forecasting for optimized energy dispatch

UNIFY ENERGY INC.

www.unifyenergy.ca

Liverpool Wind Energy Storage Project

Project Timeline

- Q1 2015: Wind Data Collection Started
- Q1 2016: Engineering Design Complete
- Q2 2016: Storage Site Preparation, WEC Site Clearing
- Q3 2016: Storage Civil and Electrical Works, WEC Site Construction
- Q4 2016: WEC Installation and Commissioned
- Q2 2017: Storage System Installation and Commissioned
- Q3 2017: WEC and Storage Commercial Operation

UNIFY ENERGY INC.

www.unifyenergy.ca

Liverpool Wind Energy Storage Project

Funding Milestones

For Unify:

Enercon Funding - June 2015

Alberta Innovates Funding - July 2015

Others - Aug/Sept 2015

For the Liverpool Project:

Watts equity raise - Nov 2015 to Feb 2016

Bank/debt financial close - Feb 2016

Others - 2016

UNIFY ENERGY INC.

www.unifyenergy.ca

Liverpool Wind Energy Storage Project

Our Partners:



UNIFY ENERGY INC.

www.unifyenergy.ca

